

Primo 6 Primo 11

Instantaneous gas water heater

Installation, operation and maintenance manual

The device is well built in accordance with the current legislation.

The CE sign positioned on the product indicates that it conforms to the following European Directives:

- Regulation Gas Appliance (UE) 2016/426
- European Standard: gas-fired instantaneous water heaters for the production of domestic hot water UNI ENI 26:2015
- Directive 2009/125/EC Ecodesign requirements for energy-related products
- Directive 2010/30/EU Indication of the consumption of energy by labelling
- Delegated regulation (EU) no. 812/2013
- Delegated regulation (EU) no. 814/2013



The appliance complies with the European Directive 2010/30/EU “ErP Energy Labelling”.

The energy label carries the information regarding the product’s energy efficiency characteristics.

In this way the end consumer can identify and compare similar products and can make informed choices regarding high efficiency appliances.

Below is a description of the label fixed to the shell of the appliance and the product sheet with the information required by the Directive.

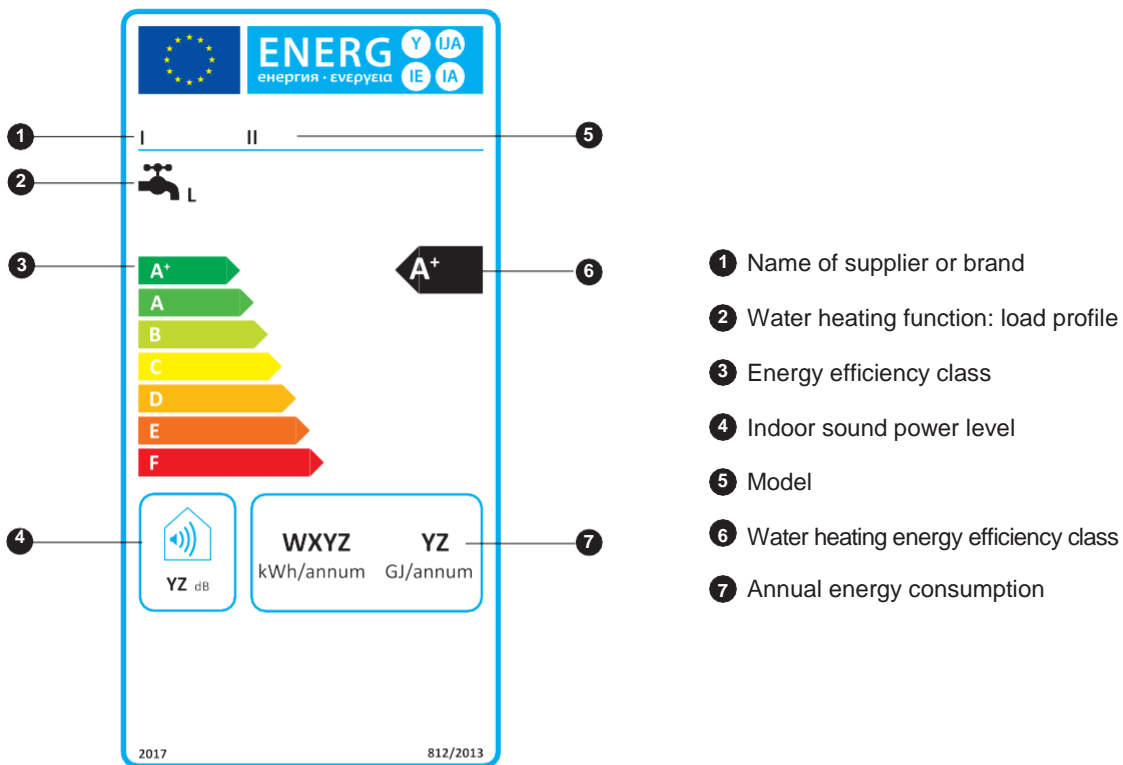

PRODUCT DATASHEET				
Innovita			Primo 6	Primo 11
2	Declared load profile		XS	M
4	Indoor sound power level	dB(A)	53	56
6	Water heating energy efficiency class		A	B
	Water heating energy efficiency class	%	41	60
7	Annual energy consumption	GJ	4	8
	Annual energy consumption	kWh	0	0
	Nitrogen oxide emissions	mg/kWh	96	103



WARNING

This booklet contains information relevant to the user as well as the installer.

The user must read the following chapters: General safety, Flue gas device and Operation.

Gas Safety (Installation and Use) Regulations 1998

In the interest of safety, it is the law that all gas appliances are installed and serviced by a competent person in accordance with the above regulations, building regulations, codes of practice and byelaws of the local water authority.

Failure to comply with the regulations may lead to prosecution. It is in your interests and that of your safety that the law is complied to.

Related documents

The following British Standards, Codes of Practice and other Regulations must be observed in the installation of the water heater.

The Gas Safety Regulations (Installation and Use) 1998

The Model Water Byelaws

Byelaws of the Local Water Undertaking

The Building Regulations (Permanent Buildings) England and Scotland.

BS 5482 Part 1 Installations in Permanent Dwellings

BS 5482 Part 2 Installations in Caravans and Non-Permanent Dwellings

BS 5482 Part 3 Installations in Boats

BS EN 1949 Installation of LPG System for Habitational Purposes in Leisure Accommodation Vehicles

EN 721 Leisure Accommodation Vehicles - Ventilation Requirements

INDEX

GENERAL SAFETY WARNINGS	page. 4
1 TECHNICAL CHARACTERISTICS	page. 6
1. a Technical Data	page. 6
2 INSTALLATION	page. 7
2. a Regulations	page. 7
2. b Wall mounting	page. 7
2. c Room ventilation	page. 7
2. d Gas Connection	page. 7
2. e Water connection	page. 8
2. f Flue gas	page. 8
3 OPERATION	page. 9
3. a Function	page. 9
3. b Usage	page. 9
4 MAINTENANCE	page. 9
4. a Removing the casing	page. 9
4. b Troubleshooting: Problems and solutions	page. 10
FOR THE ENGINEER	
Starting up the appliance and final checks	page. 11
WARRANTY	page. 12

In parts of the manual the following symbols are used:



WARNING = for actions that require caution and adequate preparation













PROHIBITED = for actions that **MUST NOT** be performed

The water heater package contains:







- 2 Two knobs to attach to the control panel after installation
- 1 Water filter to insert in the water valve pipe fitting.

GENERAL SAFETY WARNINGS

The Operation Manual is an integral part of the product and so must be carefully preserved in order to accompany the product; if it is lost or damaged another copy can be requested from Morco Products Limited on 01482 325 456 or visit our website www.morcoproducts.co.uk.

-  The installation of the device and any other repairs or maintenance must be performed by qualified personnel according to the law in force, in compliance with the installing regulations including any revisions.
-  A gas safe engineer must commission this device.
-  The device must be used according to the manufacturer specifications. The manufacturer cannot be held contractually or otherwise responsible for damage caused to persons, animals or objects as a result of incorrect installation, repair or maintenance or improper usage.
-  The product's safety or automatic regulation devices must not be modified unless performed by the manufacturer.
-  This device is intended for heating water and therefore must be connected to a water distribution network who's load and settings are compatible with the product.
-  If water leaks, turn off the water supply and advise the qualified personnel on the site.
-  If the machine is not used for prolonged periods turn off the gas supply. If there is a risk of the water freezing, empty the water heater. Please see danger of freezing on page 9.
-  If the machine breaks down or does not function properly, deactivate it, do not attempt to perform any repairs.
-  The machine's maintenance must be performed at least once a year.
-  When the product has reached the end of its serviceable life, it shall be disposed of in an environmentally friendly way; ensuring that the majority of the product is fully recycled.

When using the device the following safety rules must be applied:

-  Do not use the machine for purposes other than those intended by the manufacturer.
-  Do not block the intake and dissipation grills or the ventilation openings in the area where the device is installed with rags, paper or any other materials.
-  If a gas leak is detected, do not switch on any electrical devices, telephones or any other objects that could produce a spark. Ventilate the area by opening the doors and windows and switch off the gas supply.
-  Do not place objects on top of the device.
-  Do not leave flammable containers or substances in the area where the device is installed.
-  Do not attempt to repair the machine if it breaks down and/or works incorrectly.
-  Children or inexperienced persons are prohibited from using the device.

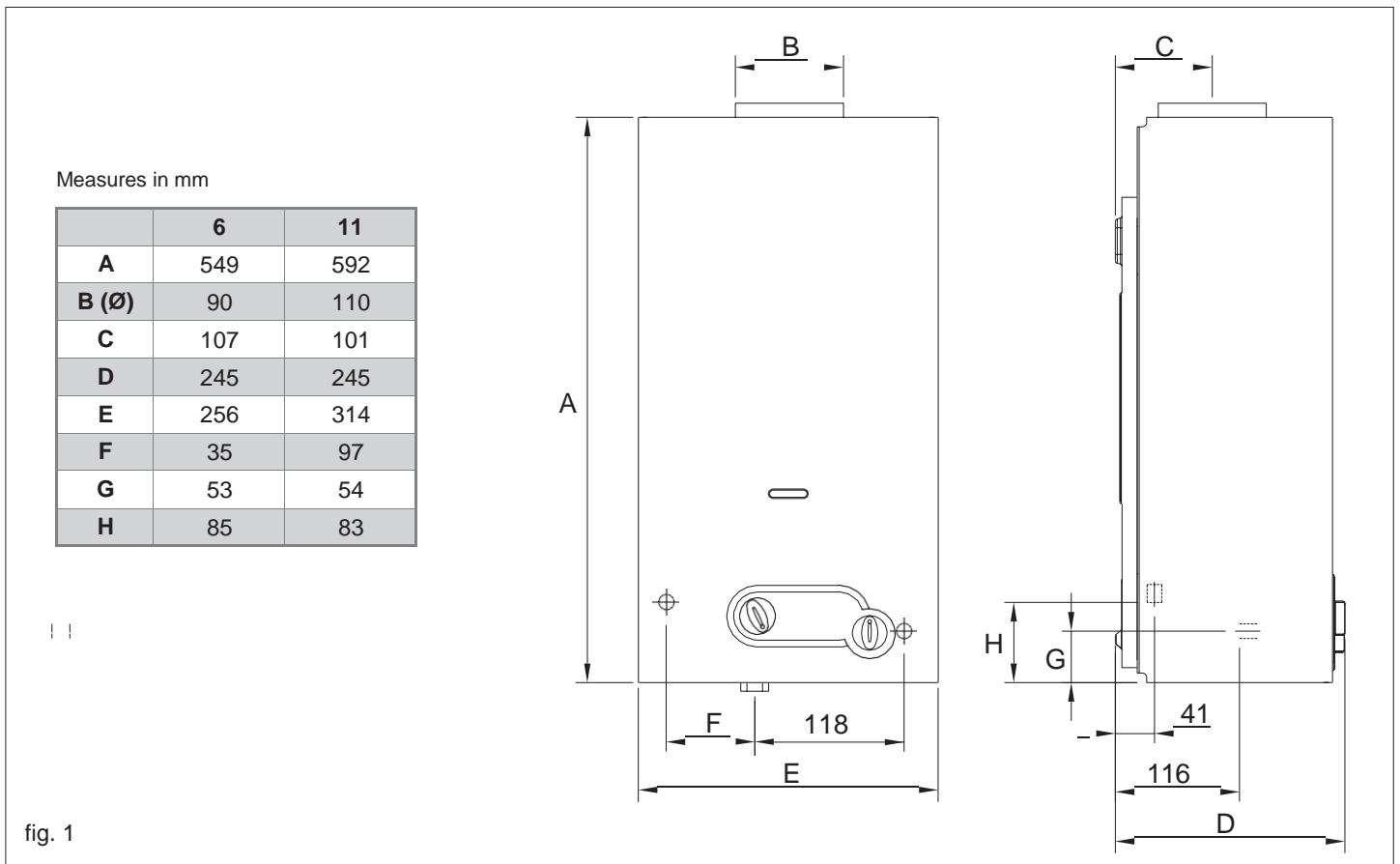
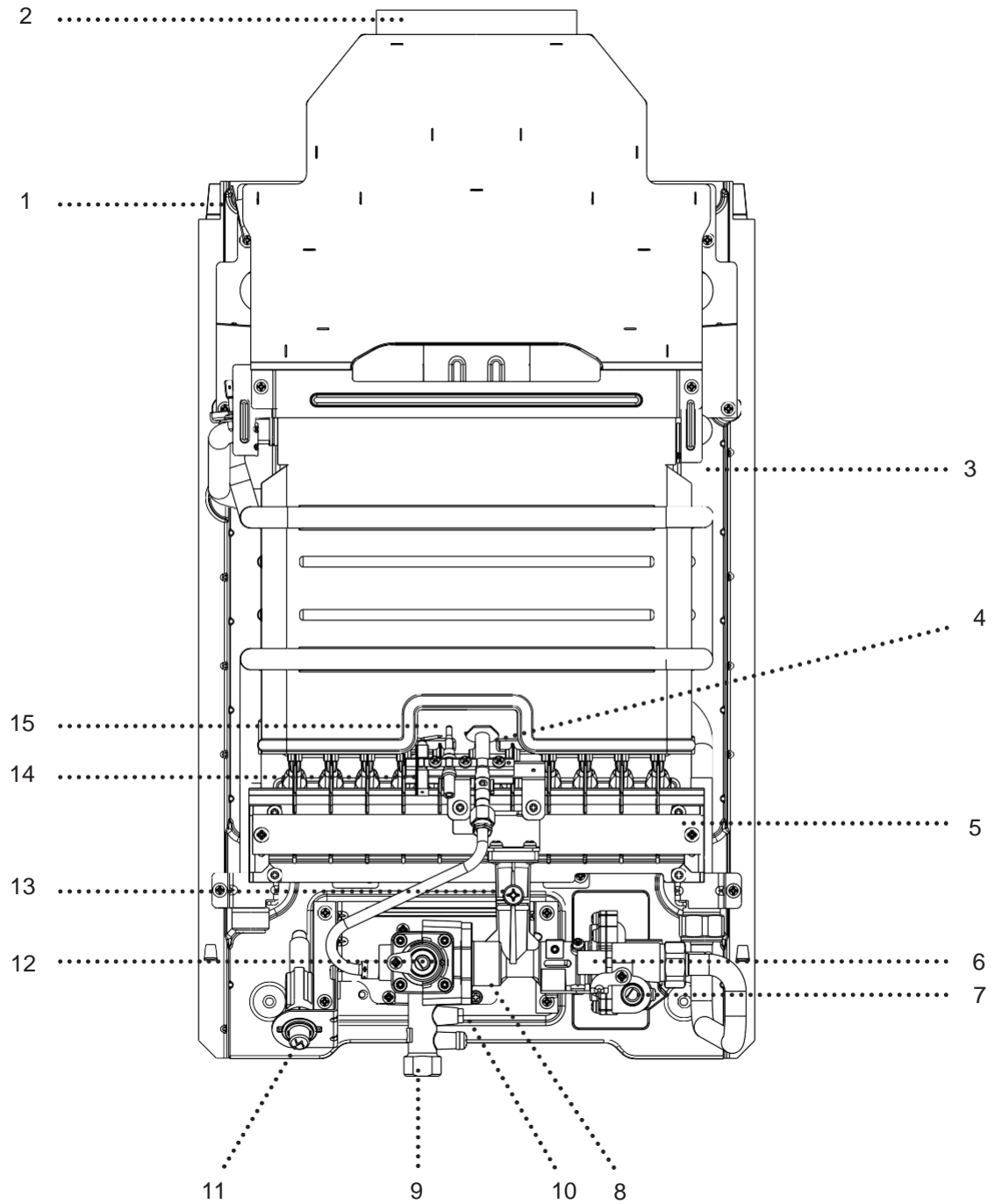

fig. 2



1	Flue gas release safety device
2	Release hood
3	Heat exchanger
4	Ignition electrode
5	Burner
6	Hydraulic valve
7	Temperature regulator
8	Gas valve
9	Gas input
10	Gas adjustment screws
11	Piezoelectric button
12	Gas control
13	Devices pressure
14	Ignition electrode
15	Thermocouple

1. TECHNICAL CHARACTERISTICS

1.a Technical Data

Primo		6		11	
		kW - kcal/h		kW - kcal/h	
Nominal power usage (Pn)		10,1 - 8.686		19,0 - 16.340	
Nominal Thermal range (Qn)		12 - 10.320		21,8 - 18.748	
Minimal power usage (Pm)		4,9 - 4.214		7,5 - 6.424	
Minimal Thermal range (Qm)		6 - 5.160		9,0 - 7.740	
GAS TYPE		BUTANE	PROPANE	BUTANE	PROPANE
		G30	G31	G30	G31
P.C.I. (15° C 1013 mbar)	MJ/m ³	116,09	88	116,09	88
WI (15° C 1013 mbar)	MJ/m ³	80,58	70,69	80,58	70,69
Consumption	kg/h	0,95	0,93	1,72	1,69
Burner Pressure	mbar	22,00	28,00	27,50	35,10
Ø pilot flame nozzle	mm	0,16		0,16	
Ø main burner nozzle	mm	0,71		0,71	
nozzles	N.	7		11	
Ø gas connection		1/2"		1/2"	
Maximum flue gas load	g/s	8,16	8,20	12,40	13,00
Flue gas temperature	°C	182	181	180	182
BE-FR-GB-IE					
Category		I3+			
Nominal feed pressure	mbar	28-30	37	28-30	37
NL					
Category		I3P			
Nominal feed pressure	mbar	-	37	-	37

WATER		6		11	
Input range	l/min	select. min. from 2 to 3	select. max 6	select. min. from 2,5 to 5	select. max from 5 to 10,8
Water temperature elevation	°C	approx. 50	approx. 25	approx. 50	approx. 25
Minimum pressure	bar	0,2		0,2	
Nominal pressure	bar	2		2	
Maximum pressure	bar	10		10	
Ø Water connections		1/2"		1/2"	
Ø flue gas release tube	mm	90		110	

DIMENSIONS AND WEIGHTS		DEVICE	PACKAGE	DEVICE	PACKAGE
Height	mm	550	612	592	655
Length	mm	256	303	314	361
Depth	mm	245	283	245	280
Weight	Kg	8,00	9,70	10,60	11,80

Note: relative cold water temperature of 15 °C

2. INSTALLATION

2.a Regulations

The use of gas devices is controlled by precise regulations. It is essential to observe regulations in force. Installation of liquid petroleum gas (L.P.G) must comply with all the distributor's requirements and those of the regulations.

2.b Wall mounting

Warning

Do not install this device in an area that contains dust, greasy vapour and/or corrosive elements.

- The device must be installed on a suitable wall surface in proximity to a fume disposal flue
- It is vital to leave the minimal distances around the device as shown in fig 3 to allow for maintenance operations to take place.

Location

The water heater requires a plentiful supply of fresh air for correct operation. Fixed ventilators or air inlets should not be obstructed.

Do not install the water heater in a location where incomplete combustion is foreseeable.

IE In bathrooms or bedrooms unless specifically allowed by national legislation.

The minimum ventilation free areas are stated in this manual and must be observed.

The water heater must be fixed to a load bearing wall in a vertical plane.

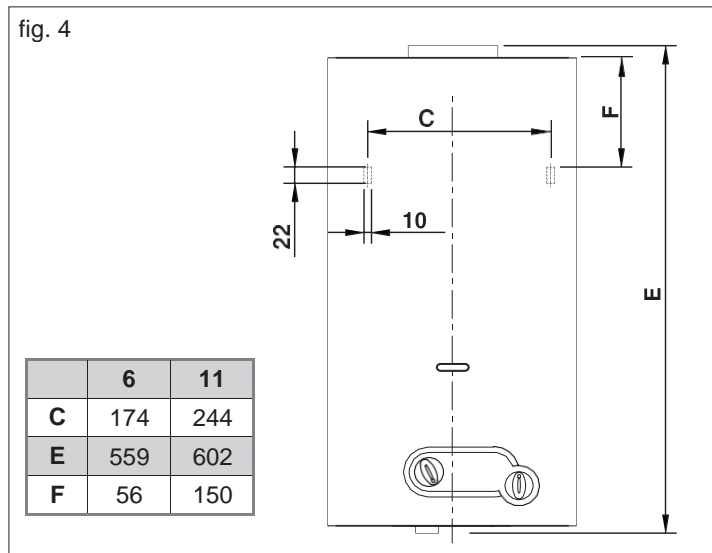
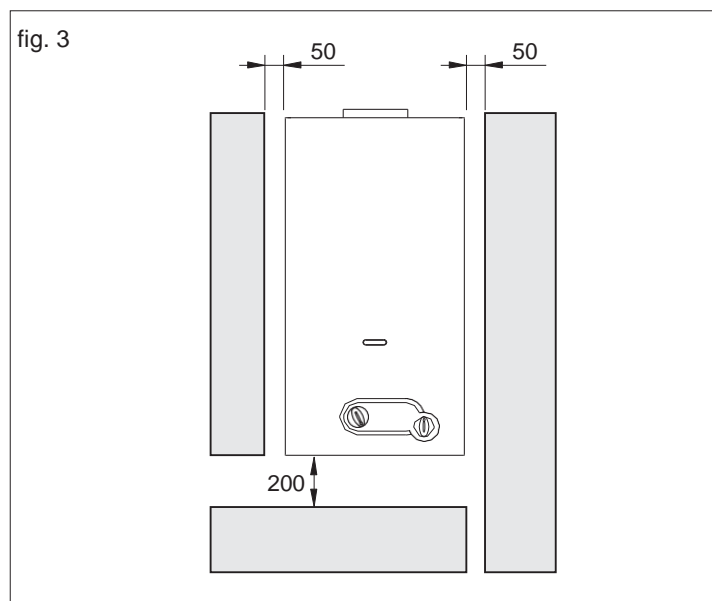

2.c Room ventilation

The installation of the water heater must comply with regulations in force including any updates. See paragraph 2.a

Warning: This device can only be installed in venues that are permanently ventilated according to regulation in force.

• COMBUSTION GAS REMOVAL

If single wall flue pipe is being used which has to pass through combustible materials, provide a metal sleeve of 115 mm dia for a Primo 6 and 135mm dia for a Primo 11 which allows an air gap of 25 mm.

Flue pipes and terminals should comply with BS 715. Terminals shall not be sited within 300 mm. of a ventilator or open window. In the U.K. full details of flueing requirements are given in BS 5440 Part 1.

• AIR SUPPLY FOR COMBUSTION

Air requirements: Reference is made to BS 5482 (BS EN 1949) and EN 721 covering ventilation requirements for permanent dwellings, caravans and boats.

Fixed ventilation should be provided to avoid draughts as far as possible without impairing the free area of ventilation, even in adverse weather conditions. If the heater is positioned in location which may be subjected to strong draughts i.e. close to a window or opening then strong draughts or gusts of wind may extinguish the pilot.

All permanent openings for ventilation should be designed to prevent the entry of vermin. Where screens are provided, they should not have apertures of less than 6 mm. or greater than 9 mm. in any direction, and they should be accessible for cleaning. Fine mesh screens shall be avoided as they are liable to become blocked with dust.

The location of vents and the method of cleaning them should be stated in the Owners Handbook (Caravans and Boats).

As a guide, the minimum effective free area of vents is stated below in connection with this water heater. Additional appliances burning gas in the same area would require additional air requirements.

1. If a Primo 6 or Primo 11 is installed in an enclosed space in a Caravan Holiday Home the required ventilation is that as specified in BS 5482 part 2, i.e. 10 cm² per kilowatt input rating divided between high and low. So the high and low should be 55.5 cm² for the Primo 6 and 114 cm² for Primo 11.

2. Where a Primo 6 is installed in an open bottomed cupboard in a Caravan Holiday Home, i.e. in a kitchen, the ventilation requirements are as stated in BS 5482 part 2. (EN 721).

2.d Gas Connection

The water heater should be connected to the gas supply via a 10mm (Primo 6) or 15mm (Primo 6 or Primo 11) diameter copper gas pipe. A gas isolation valve must be fitted to the gas inlet on the water heater.

When installing or commissioning the water heater the following must be observed:

- The diameter of the gas pipe between the supply bottle or tank must be in accordance with the regulations in force
- The regulator size and pressure specification are correct for the application
- The correct gas (LPG) is being supplied
- All the required gas pressure and tightness tests are carried out as part of the commissioning process.
- Gas joints downstream of the magnetic gas valve must be checked with leak detection fluid while the heater is running
- Gas jointing paste should not be used when connecting the gas isolation valve

Do not obstruct the area's ventilation openings where the device is installed to avoid dangers such as the build up of toxic and explosive substances. Do not utilize gas tubes to earth electrical devices.

2.e Water connection

Connect the water heater to the water supply.

From the front, the cold water input is on the right and the hot water output is on the left.

⚠ Insert the filter into the water valve input fitting.

⚠ Remove the plastic nut from the hot water output fitting before connecting it to the water supply.

Ensure that the tubes of your water system are not used to earth your electrical system or telephone, they are absolutely inappropriate for performing this task.

In a short amount of time this can damage tubes and the device.

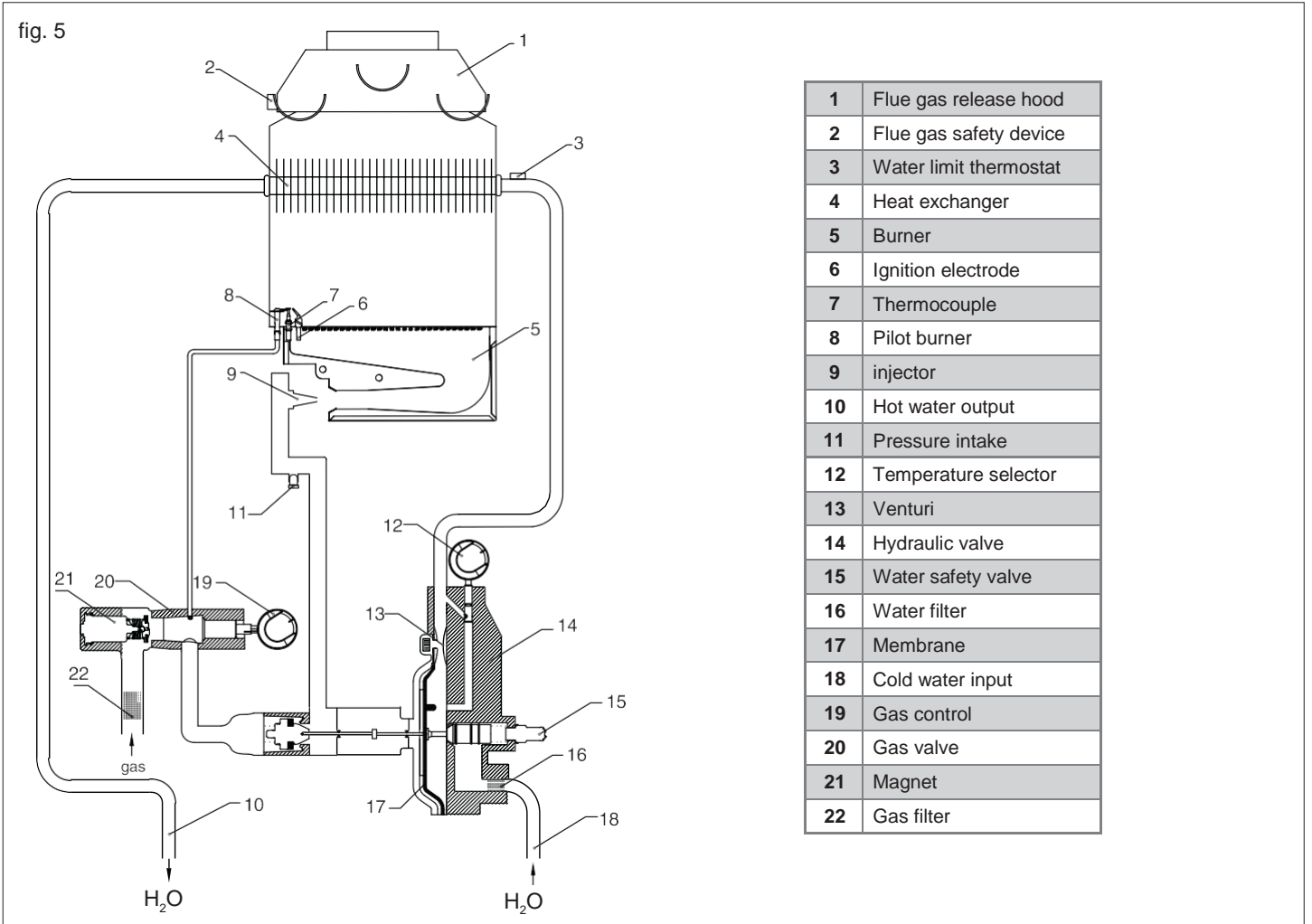

2.f Flue Gas

For output of flue gases refer to the regulations in force including any updates. See paragraph 2.a.

The water heater must be connected to a suitable flue terminal. The following must be observed:

- The flue must be installed vertically – through the roof of the holiday home
- The diameter of the flue terminal must match that of the water heater (90mm for the Primo 6 litre or 110mm for the Primo 11 litre)
- The overall flue length from the top of the water heater to the top of the external flue must be at least 600mm. The distance from the external roof surface to the top of the external flue must be at least 250mm.

flue gases to leave safely. The device will also operate if the design or length of the flue is not to the correct standard. This stat will reset when the blockage is removed allowing the water heater to operate as normal.

The hi limit stat is failsafe so that it will need to be replaced if faulty before the water heater will function again. The stat must not be removed or altered in any way otherwise the operation of the water heater may become dangerous.

Flue gas safety device

This product is equipped with a flue gas safety device. The device ensures the flue gases leave the water heater safely via the flue. The flue safety device marked as 2 in Fig.5 is a hi limit stat that will interrupt the flow of gas to the water heater burner and pilot light if there is a total or partial blockage in the flue that does not allow the

3. OPERATION

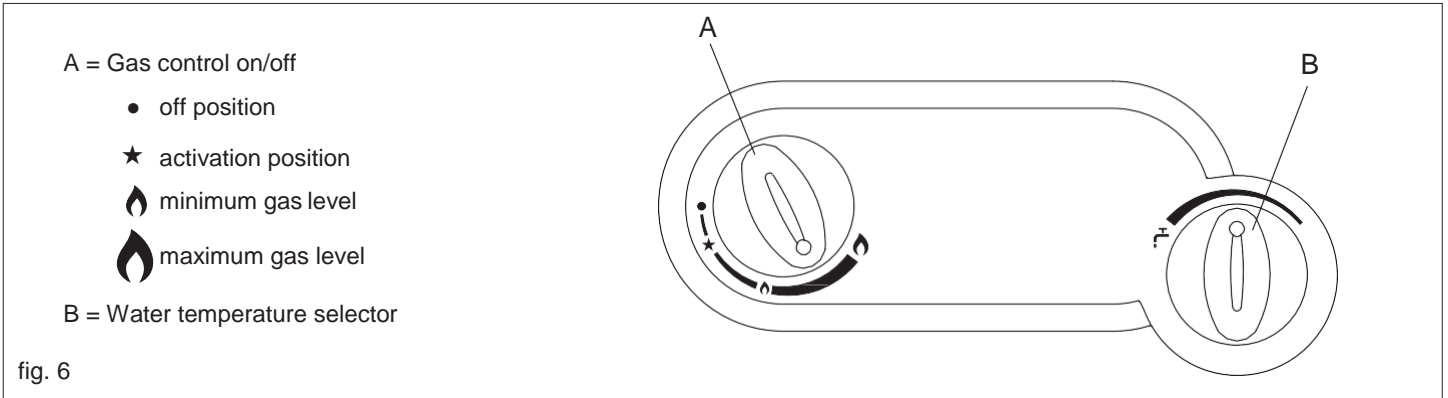

fig. 6

3.a. Function

The water heater is designed to produce instantaneous hot water. The hot water is delivered to several outlets around the home. If more than one outlet is used at any one time the delivery of hot water will be reduced at each outlet. The Water heater has 2 main controls:

- A gas control knob - "A" in Fig 6
- A water temperature control knob – "B" in fig 6

The minimum gas level in fig. 6 will provide approximately 50% of the available power. Turning the gas control knob counter-clockwise will increase the power level between 50% and 100%. This function may be useful to vary the temperature of the water supplied.

The water temperature selector allows water to be supplied anywhere between 50% and 100% of the water heater's capability. In effect the selector reduces the water flow through the heater to the taps to increase the water temperature and increases the water flow to reduce the water temperature.

In the UK the normal positions for the controls are:

- Gas control – always set to 100% (fully counter clockwise)
- Water control set to 100% (fully counter clockwise) during the winter months
- Water control set to between 100% and 50% during the summer months to suit the customer's preference for hot water temperature.

3.b Usage

Ensure that the gas tap and all water taps are switched off

- Turn on the Main external gas supply tap on the bottle or tank
- Open the gas tap, not supplied with the device, placed immediately before the water heater on the gas input pipe
- Rotate knob A to the on position (★), press the knob down all the way and keep it pressed
- Press the piezo electric button that is located under the water heater on the right-hand side until the spark ignites the pilot flame. The flame can be seen through the viewing window on the front of the heater. When it ignites, keep the gas control knob ("A" in fig 6), pressed for 20-30 seconds. If the pilot does not stay lit when the knob is released, repeat the procedure
- Rotate Knob A towards the large flame (🔥), during rotation it is necessary to keep the knob pressed down lightly until the final position is reached
- From this moment the device is able to produce hot water on request. Opening the hot water tap causes the main burner to be ignited, and inversely, by closing the hot water tap the main burner is switched off; but the pilot flame remains switched on for future requests
- If the main burner or pilot flame is accidentally turned off, the gas valve automatically blocks the output of gas within 60 seconds so to avoid any danger. To return the device to an operational mode, repeat the steps above.

The machine is switched off by rotating knob A to the OFF position (●).

When the water heater is not used for long periods close the gas supply tap or the LPG gas valve on the tank. For the best operational results it is recommended to have a qualified technician service the machine at least once a year

PRECAUTIONS TO BE TAKEN AGAINST FROST AND FREEZING CONDITIONS

If there is a possibility that the area where the device is stalled could reach below 0°C, the device must be emptied of all water contained.

During cold spells, if your appliance is located in a place exposed to frost and freezing conditions, it must be drained down in the following way:

- Turn off the appliance's water inlet stopcock.
- Open any drain cocks located on the installation pipework
- Turn on all hot and cold water taps.
- Turn temperature selector fully anticlockwise.
- When this operation has been completed, turn off the hot and cold water taps.

To start up the appliance again, open its water inlet stopcock

4. MAINTENANCE

To maintain the machine at maximum efficiency, have qualified personnel perform a maintenance check at least once a year.

Before cleaning or performing maintenance, opening or disassembling the panels, switch off the device and turn off the gas supply. Check the main burner and the pilot flame, the ignition electrode, the safety valve and that there is no leakage. Check that there is nothing obstructing the passages within the exchanger smoke channel.

To clean the outside of the panels utilize a cloth with soap and water. Do not use solvents, powders or abrasive sponges.

Do not clean the device and/or its parts with flammable materials (e.g. petrol, alcohol, diesel etc.).

4.a Removing the casing

To remove the outer casing follow the steps below:

- Remove the selector knobs (A and B)
- Remove the screws (C)
- Shift the casing upwards to free it from the upper and lateral hooks
- Shift the casing forwards
- To reinsert the casing, follow the above steps in reverse order.

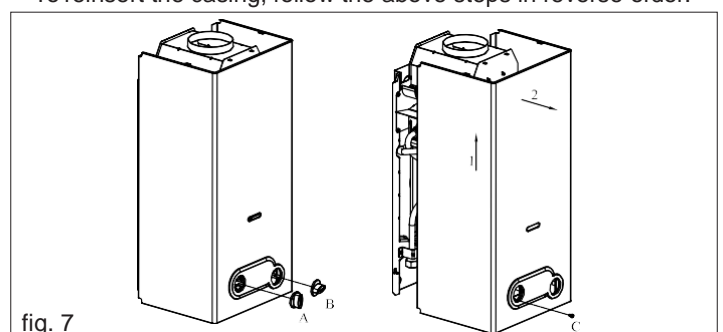

fig. 7

4.b Troubleshooting: problems and solutions

For the best functioning of the water heater, to prolong its lifetime and ensure that it is always safe, ensure that it is inspected at least once a year by a gas safe engineer. The gas safe engineer is to perform the following maintenance operations:

- Remove any rust from the burner
- Remove any deposit on the glow plug by the electrode

- Clean the combustion chamber
- Check the ignition, switching off and general functionality of the device
- Check that the gas and water tubes and connections are sealed

Warning: the following repair instructions are only to be performed by qualified and authorized technicians.

PROBLEM	CAUSE	SOLUTIONS
There is no spark	<ul style="list-style-type: none"> - electrical cable of device is disconnected - piezoelectric mechanism broken - piezoelectric mechanism is not earthed - the electrode is damaged 	<ul style="list-style-type: none"> - insert - test, substitute - test - substitute
The pilot does not switch on when there is a spark	<ul style="list-style-type: none"> - pilot nozzle obstructed - electrode activation position - no gas supply - air in the gas tubes 	<ul style="list-style-type: none"> - clean by blowing - adjust - open the gas tap - bleed air by turning on all gas rings on hob for 30 seconds
The pilot does not stay on	<ul style="list-style-type: none"> - thermocouple faulty - broken magnet 	<ul style="list-style-type: none"> - substitute - substitute
Pilot on but the main burner does not ignite	<ul style="list-style-type: none"> - insufficient water pressure - the diaphragm is broken 	<ul style="list-style-type: none"> - repair the device pressure - rotate the knob B counter clockwise - substitute
The burner does not switch off when the water turns off	<ul style="list-style-type: none"> - grime on the gas shutter - valve piston or stem is locked in open position - If an LPG supply, check the gas pressure 	<ul style="list-style-type: none"> - test, clean - disassemble, clean and eventually substitute - regulate and if necessary substitute the tank pressure regulator
Delayed burner activation	<ul style="list-style-type: none"> - pilot burner flame is too far from main burner flame or is too short 	<ul style="list-style-type: none"> - regulate the flame, clean injector and pilot burner
The exchanger blade becomes dirty in a small amount of time	<ul style="list-style-type: none"> - poor draught or dusty surroundings - yellow flame - excess gas consumption 	<ul style="list-style-type: none"> - check the flue installation - check the gas type and clean the burner - check and regulate
There is a smell of gas	<ul style="list-style-type: none"> - due to the loss of gas in the tubes, check the tubes and find the leak 	<ul style="list-style-type: none"> - do not activate electric switches or any object that produces sparks in local area
There is a smell of gas	<ul style="list-style-type: none"> - it can be caused by obstruction in the flue gas circuit - excess gas consumption 	<ul style="list-style-type: none"> - check the flue installation - check and regulate

FOR THE ENGINEER

STARTING UP THE APPLIANCE AND FINAL CHECKS

Start the appliance by following the directions given in section 3b, "Usage", checking that the appliance is working correctly. Pay special attention to the colour of the flames ensuring there is no yellowness which would indicate burner venturis blocked by insect matter.

Check the gas operating pressures with the heater under full power at the inlet pressure nipple located on the right hand side of the gas body valve stem. The pressure drop should not exceed 2.5 mb below that specified in this manual.

Check the burner pressure with the heater at full load at the test nipple located on the left hand side of the main gas valve body below the main burner. These pressures must at least be equal those specified in this manual in order to achieve the desired performance specified in this manual.

These gas water heaters are set in the factory for use with the gas they are intended to burn. The gas for which each appliance is set is indicated on the packaging and on the cover of the heater itself.

Check the flue for spillage: close all the doors and windows in the room containing the water heater. If there are any fans or extractors in the room then these must be turned on full. Light any other open flued appliances such as fires or gas hobs. Turn the water heater on by opening a hot tap on full burn and run for 5 minutes to allow the flue to warm up.

Hold a smoke match to the side of the opening of the draught diverter using an extended holder, making sure that the end of the match is located centrally in the draught diverter.

The smoke should be pulled up the flue and not back into the room. If spillage is detected, run the appliance for a further 10 minutes and then repeat the test. If spillage is still detected then check the flue for blockages, check that the correct flue terminal is fitted and that the correct ventilation is fitted at a low and high level. Also check the ventilation has not been blocked.

A.2.3. - LOOKING AFTER THE APPLIANCE

• PRECAUTIONS

– Against furring up (lime scale)

If the appliance is installed in an area with very hard water, with time, the following may occur:

- A fall in the hot water temperature, or
- A reduction in the hot water flow.

This means that the heat exchanger may be furred up, creating the above situations

As the level of scale build up is proportional to the selected outlet temperature, (the hotter the water the greater the scale build up) In order to reduce scale build up it is recommended that the water temperature required at the outlet is achieved by selecting the desired temperature at the heater, and not by mixing cold water to hot water in order to obtain the correct temperature i.e. for showering purposes.

Note: Defurring/descaling should be carried out using proprietary agent or dilute hydrochloric acid. It is recommended to circulate the descaling fluid around the heat exchanger in order to speed up the process. Depending on the amount of scale build up and the strength of the descaling solution the time to totally descale could be up to two hours.

• MAINTENANCE

• MINIMUM ANNUAL MAINTENANCE

Gas water heaters are rugged pieces of equipment which are designed to work for a long time with minimum maintenance requirements. The only regular maintenance required is the (annual) cleaning of the heating body and the burner. If the appliance is installed in a caravan or boat it is essential this is done at the beginning of each season.

• CLEANING THE MAIN BURNER

To carry out the annual cleaning of the burner, proceed as follows:

- Turn off the gas supply, remove the cover and remove the burner.
- Clean the surface of the burner heads gently with a brush. Then blow through them to remove any particles of dust loosened during the brushing operation.
- Check the venturis for contamination from insects and spiders webs.

• CLEANING THE HEAT EXCHANGER

To carry out the annual cleaning of the heating body, proceed as follows:

- Turn off the gas supply
- Turn off the supply of water to the appliance by turning off the appliance's water inlet tap.
- Turn on all the hot water taps to empty all the pipes.
- Remove the heating body and clean it by gently brushing the fins. Soot if found should be removed by washing, and the cause of the sooting investigated.

• CLEANING THE PILOT

If the pilot light flame is yellow and the safety valve takes a long time to open, this means that either the pilot injector or pilot burner is partially blocked.

The pilot injector may be blocked with contaminants carried within the gas, whilst the pilot burner is more likely to be contaminated by insects (spiders / egg sacs)

N.B. No attempt should be made to clear blocked or partially blocked pilot injectors by using wire. If blowing through the injector fails to clear the restriction, then a new injector should be fitted.

When the pilot is working normally the flame should be a stable blue coloured cone shape. To clean the pilot burner, proceed as follows:

- Turn off the gas supply, remove the front cover. Remove the pilot injector, by slackening the supply pipe nut first, and unscrewing the pilot injector from the pilot burner
- Remove the contamination from within the pilot burner using wire, and blow through to remove any further debris.
- Replace the pilot injector, ensuring that the washers are properly fitted.

WARRANTY

The water heater is guaranteed against manufacturing defects for one year from first commissioning date. However the guarantee is subject to proof of commissioning in accordance with the gas safety (Installation and Use) act of 1998. The guarantee does not cover defects caused by lack of maintenance.

Morco Products Ltd. warranty will cover parts and labour if the appliance has been fitted as part of the original equipment in a caravan holiday home or leisure accommodation vehicle.

Appliances distributed as non original equipment either directly from Morco Products Ltd. or other merchants are subject to a return to base policy for repair and return at the expense of Morco Products Ltd.

As an alternative to returning the appliance for repair we will supply spare parts and advice for defective appliances on the provision that we can talk to the competent registered gas engineer involved in the fitting or repair of the defective appliance

No remuneration will be offered for the removal and refitting of the appliance or for any work / travelling involved in the fitting of spare parts supplied by ourselves.

Exclusions from warranty

- Damage caused by frost
- Scaling up of the heat exchanger
- Blocked pilot injectors
- Insect or debris in the burner or heat exchanger
- Blocked gas or water filters
- Incorrect operation caused by damaged mixer taps or shower TMV2

Supplied by Innovita Italy

Distributed in U.K. by:

MORCO PRODUCTS LTD

Morco House
Riverview Road
Beverley
East Yorkshire
HU17 0LD
ENGLAND

Telephone Number: 01482 325456

Fax Number: 01482 212869

Web Address: www.morcoproducts.co.uk